

> PR-AC

Ventilatori centrifughi in materiale plastico

Centrifugal fans in plastic material



DESCRIZIONE GENERALE

La serie PR-AC è particolarmente adatta a convogliare fumi e vapori corrosivi (non abrasivi) o ad alto tasso di umidità con temperatura del fluido di 60°C max. Il PR-AC è un ventilatore centrifugo a pale rovesce in materiale plastico con caratteristiche tecniche e meccaniche che permettono una durata nel tempo. La girante a pale rovesce conferisce a questa serie buone caratteristiche di silenziosità ed efficienza aeraulica. Il PR-AC, quando ha terminato il suo ciclo vitale, è facilmente smaltibile, grazie ai materiali riciclabili con cui è costruito.

COSTRUZIONE

- Cassa a spirale realizzata in polietilene (PE).
- Girante a semplice aspirazione, realizzata in polipropilene (PP), con pale rovesce e mozzo in alluminio protetto dal fluido trasportato.
- Sedia portamotore realizzata in lamiera d'acciaio e verniciata a polveri epossipoliestiriche.
- motore asincrono trifase o monofase a norme internazionali IEC 60034, IEC 60072, EMC 2004/108/CE, LVD 2006/95/CE e marcato CE IP55, classe F, forma B3 o B5. Idoneo ad un servizio S1 (funzionamento continuo a carico costante).

ACCESSORI

- Rete di protezione per bocca aspirante e premente realizzata a norma UNI 10615.
- Giunto antivibrante in PVC per bocca aspirante e premente.
- Serranda a gravità.
- Serranda di taratura manuale.

A RICHIESTA

- Versione con cassa realizzata in PP, polipropilene (PR-AC/PP).
- Versione con cassa realizzata in PER, polietilene antistatico e autoestinguente (PR-AC/PER).
- Versione con sedia in acciaio inossidabile AISI 304.
- Versione PR-AC ATEX questa serie può essere impiegata in aree in cui è probabile la presenza di atmosfere potenzialmente esplosive, causate da gas, vapori e nebbie (gruppo II, categoria 3G). Motore asincrono trifase o monofase a norme internazionali IEC 60034, IEC 60072, IEC 60079 e/o IEC 61241, EMC 2004/108/CE, LVD 2006/95/CE, con certificati ATEX e marcatura CE, IP 55, classe F, forma B3 o B5.

GENERAL DESCRIPTION

The PR-AC series is particularly designed for conveying smoke and corrosive vapours and smokes, also with high humidity level and with maximum fluid temperature of 60°C. The PR-AC is a centrifugal backward curved fan with technical and mechanical characteristics that grant a long lasting operation. The backward curved impeller provide good characteristics of low noise and high efficiency. The PR-AC fan, when its lifetime is finished, is easy to dispose, being manufactured with recyclable materials.

CONSTRUCTION

- Volute in polyethylene (PE).
- Single inlet impeller, in Polypropylene (PP), with backward curved blades and aluminium hub (protected from the fluid).
- Motor support in epoxy painted steel sheet.
- Asynchronous three-phase or single-phase motors according to international standards IEC 60034, IEC 60072, EMC 2004/108/CE, LVD 2006/95/CE, CE marked, IP 55, class F, B3 or B5 shape. Suitable to a S1 service (continuous working to constant load).

ACCESSORIES

- Inlet protection guard according to UNI 10615.
- Anti-vibration joint in PVC for inlet and outlet sides.
- Gravity shutter.
- Manual setting shutter.

UPON REQUEST

- Version with casing in PP, Polypropylene (PR-AC/PP).
- Version with casing in PER, anti-static and self-extinguishing polyethylene (PR-AC/PER).
- Version with motor support in stainless steel AISI304.
- PR-AC ATX series is suitable in zones or environments where it is necessary to guarantee security against explosions and fires due to gas (II3G). Asynchronous three-phase motors or single-phase according to international standards IEC 60034, IEC 60072, IEC 60079 and/or IEC61241, EMC 2004/108/CE, LVD 2006/95/CE, with ATEX certification, CE marked, IP55, class F, B3 or B5 shape.

ORIENTAMENTI Discharge angles

PR-AC

Rotazione Rotation RD						
Forma/Form	0	45°	90°	135°	270°	315°
Rotazione Rotation LG						

N.B.: Orientamento standard LG270°
Standard discharge angles LG 270°



Frequenza 50Hz – Temperatura dell'aria 15°C – Pressione barometrica 760 mm Hg – Peso specifico dell'aria 1,22 Kg/m³
 Frequency 50Hz – Air temperature 15°C – Barometric pressure 760 mm Hg – Air specific weight 1,22 Kg/m³

Lp: livello di pressione sonora rilevato a 1,50 m - **Lp:** sound pressure level measured at 1,50 m

PR-AC 200							
Tipo Type	Modello Model	U	P	Pm (kW)	In (A)	IP/CL	Lp dB(A)
PR-AC	202	M	2	0,18	1,28	55/F	56
PR-AC	202	T	2	0,18	0,60	55/F	56
PR-AC ATX	202	T	2	0,18	0,64	55/F	56

Limiti d'impiego - Operational limit							
Tipo Type	Modello Model	Q max (m ³ /h)	Pt min (mm H ₂ O)	C max (m/s)	S (m ²)	Pd ² (kgm ²)	Mot. (Gr)
PR-AC	202	920	11	12,72	0,0200096	0,0132	63

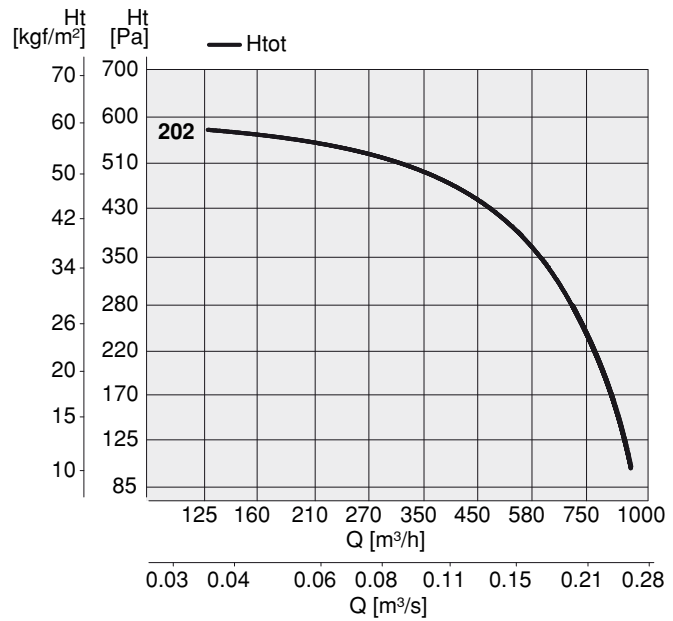

PR-AC 250							
Tipo Type	Modello Model	U	P	Pm (kW)	In (A)	IP/CL	Lp dB(A)
PR-AC	252	M	2	0,37	3,00	55/F	70
PR-AC	252	T	2	0,37	1,10	55/F	70
PR-AC	254	M	4	0,12	1,10	55/F	53
PR-AC	254	T	4	0,12	0,45	55/F	53
PR-AC ATX	252	T	2	0,37	0,97	55/F	70
PR-AC ATX	254	T	4	0,12	0,47	55/F	53

Limiti d'impiego - Operational limit							
Tipo Type	Modello Model	Q max (m ³ /h)	Pt min (mm H ₂ O)	C max (m/s)	S (m ²)	Pd ² (kgm ²)	Mot. (Gr)
PR-AC	252	2050	21	18,14	0,0314	0,032	71
PR-AC	254	980	5	8,69	0,0314	0,032	63

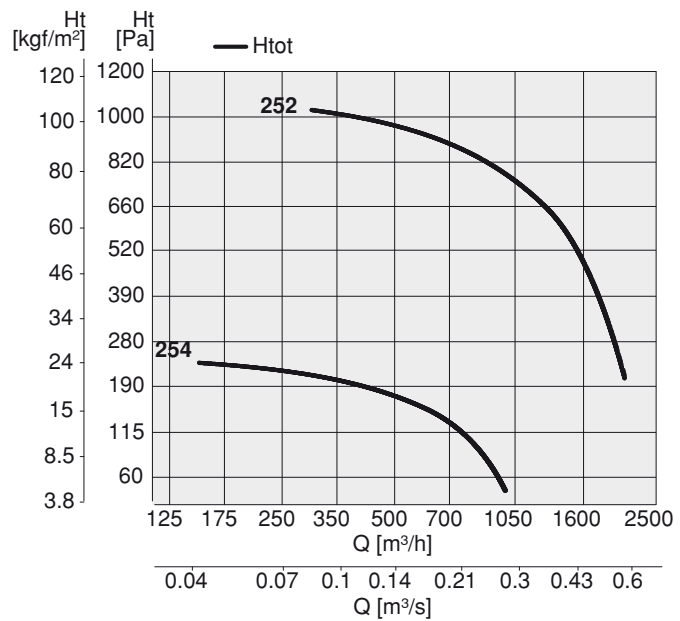

PR-AC 280							
Tipo Type	Modello Model	U	P	Pm (kW)	In (A)	IP/CL	Lp dB(A)
PR-AC	282	M	2	0,75	5,20	55/F	74
PR-AC	282	T	2	0,75	1,90	55/F	74
PR-AC	284	M	4	0,18	1,60	55/F	56
PR-AC	284	T	4	0,18	0,60	55/F	56
PR-AC ATX	282	T	2	0,75	1,73	55/F	74
PR-AC ATX	284	T	4	0,18	0,68	55/F	56

Limiti d'impiego - Operational limit							
Tipo Type	Modello Model	Q max (m ³ /h)	Pt min (mm H ₂ O)	C max (m/s)	S (m ²)	Pd ² (kgm ²)	Mot. (Gr)
PR-AC	282	2740	22	19,00	0,04	0,069	80
PR-AC	284	1280	5	8,887	0,04	0,069	63

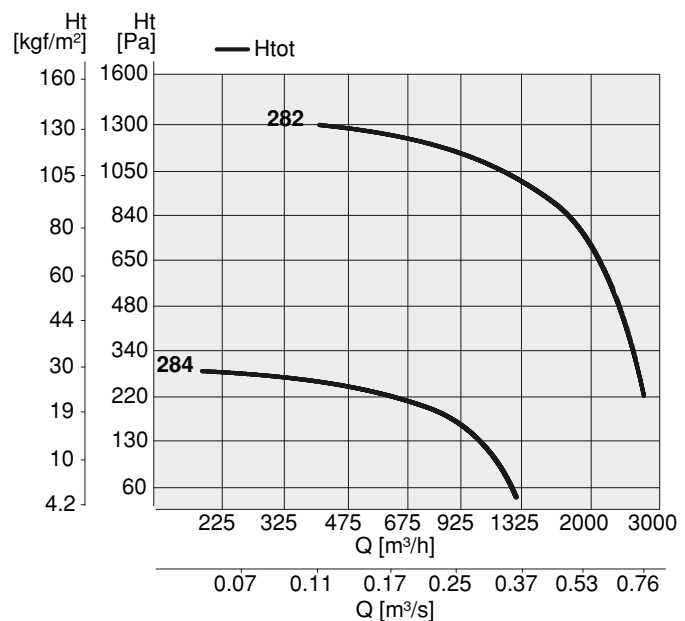



Frequenza 50Hz – Temperatura dell'aria 15°C – Pressione barometrica 760 mm Hg – Peso specifico dell'aria 1,22 Kg/m³
 Frequency 50Hz – Air temperature 15°C – Barometric pressure 760 mm Hg – Air specific weight 1,22 Kg/m³

Lp: livello di pressione sonora rilevato a 1,50 m - **Lp**: sound pressure level measured at 1,50 m

PR-AC 310							
Tipo Type	Modello Model	U	P	Pm (kW)	In (A)	IP/CL	Lp dB(A)
PR-AC	312	M	2	1,50	10,00	55/F	77
PR-AC	312	T	2	1,50	3,40	55/F	77
PR-AC	314	M	4	0,25	2,40	55/F	59
PR-AC	314	T	4	0,25	0,85	55/F	59
PR-AC	316	T	6	0,18	0,70	55/F	49
PR-AC ATX	312	T	2	1,50	3,34	55/F	77
PR-AC ATX	314	T	4	0,25	0,89	55/F	59
PR-AC ATX	316	T	6	0,18	0,69	55/F	49

Limiti d'impiego - Operational limit							
Tipo Type	Modello Model	Q max (m ³ /h)	Pt min (mm H ₂ O)	C max (m/s)	S (m ²)	Pd ² (kgm ²)	Mot. (Gr)
PR-AC	312	4180	35	23,72	0,0490625	0,106	90S
PR-AC	314	1980	8	11,20	0,0490625	0,106	71
PR-AC	316	1256	3	7,113	0,0490625	0,106	71

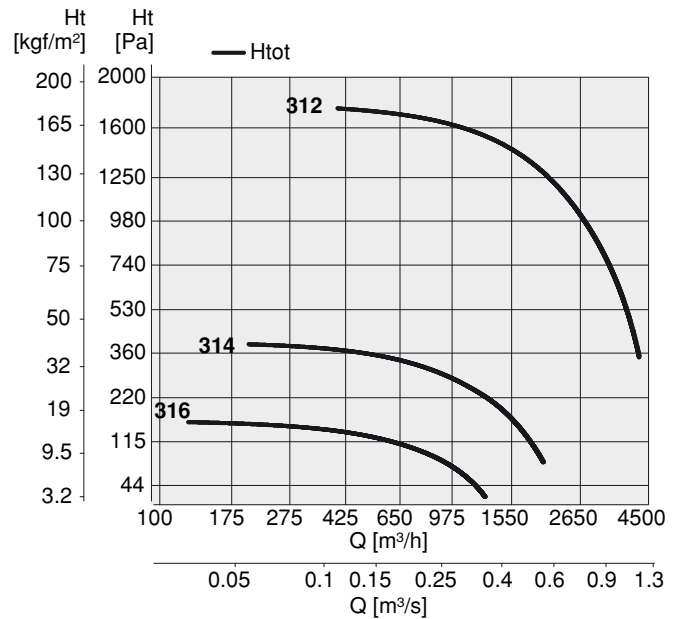

PR-AC 350							
Tipo Type	Modello Model	U	P	Pm (kW)	In (A)	IP/CL	Lp dB(A)
PR-AC	352	T	2	2,20	4,90	55/F	78
PR-AC	354	M	4	0,37	2,90	55/F	61
PR-AC	354	T	4	0,37	1,18	55/F	61
PR-AC	356	T	6	0,18	0,70	55/F	50
PR-AC ATX	354	T	4	0,37	1,22	55/F	61
PR-AC ATX	356	T	6	0,18	0,69	55/F	50

Limiti d'impiego - Operational limit							
Tipo Type	Modello Model	Q max (m ³ /h)	Pt min (mm H ₂ O)	C max (m/s)	S (m ²)	Pd ² (kgm ²)	Mot. (Gr)
PR-AC	352	5610	41	25,14	0,062	0,182	90L
PR-AC	354	2690	9	12,07	0,062	0,182	71
PR-AC	356	1670	4	7,491	0,062	0,182	71

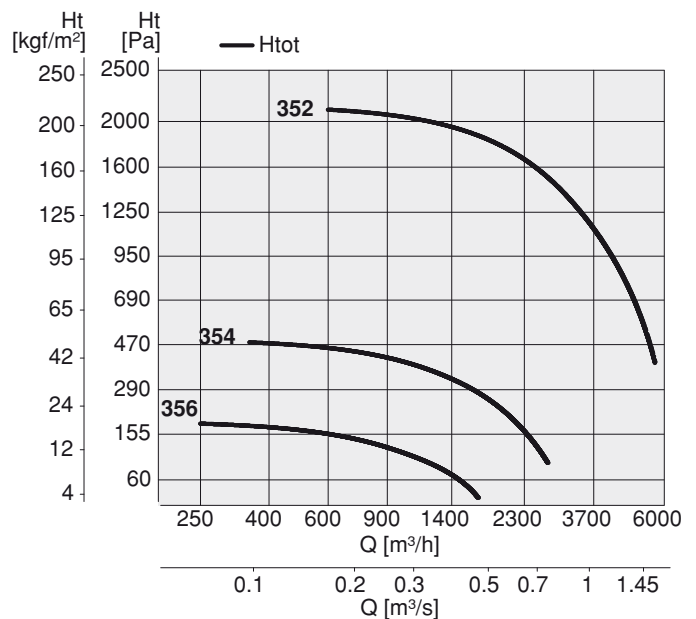



Frequenza 50Hz – Temperatura dell'aria 15°C – Pressione barometrica 760 mm Hg – Peso specifico dell'aria 1,22 Kg/m³
 Frequency 50Hz – Air temperature 15°C – Barometric pressure 760 mm Hg – Air specific weight 1,22 Kg/m³

Lp: livello di pressione sonora rilevato a 1,50 m - **Lp:** sound pressure level measured at 1,50 m

PR-AC 400

Tipo Type	Modello Model	U	P	Pm (kW)	In (A)	IP/CL	Lp dB(A)
PR-AC	404	M	4	0,55	4,30	55/F	66
PR-AC	404	T	4	0,55	1,60	55/F	66
PR-AC	406	T	6	0,25	1,00	55/F	55
PR-AC ATX	404	T	4	0,55	1,75	55/F	66
PR-AC ATX	406	T	6	0,25	0,89	55/F	55

Limiti d'impiego - Operational limit

Tipo Type	Modello Model	Q max (m ³ /h)	Pt min (mm H ₂ O)	C max (m/s)	S (m ²)	Pd ² (kgm ²)	Mot. (Gr)
PR-AC	404	3580	10	12,77	0,078	0,311	80
PR-AC	406	2220	4	7,912	0,078	0,311	71

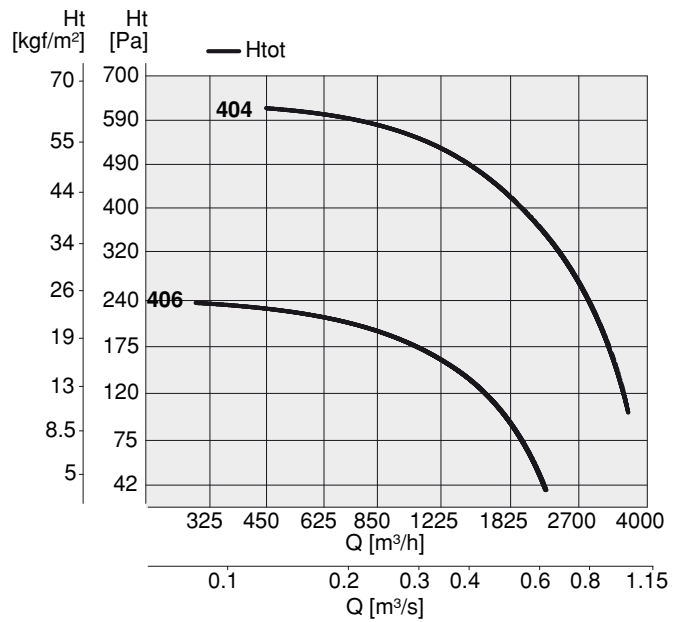

PR-AC 450

Tipo Type	Modello Model	U	P	Pm (kW)	In (A)	IP/CL	Lp dB(A)
PR-AC	454	T	4	1,10	2,70	55/F	66
PR-AC	456	T	6	0,37	1,20	55/F	56
PR-AC ATX	454	T	4	1,10	2,80	55/F	66
PR-AC ATX	456	T	6	0,37	1,37	55/F	56

Limiti d'impiego - Operational limit

Tipo Type	Modello Model	Q max (m ³ /h)	Pt min (mm H ₂ O)	C max (m/s)	S (m ²)	Pd ² (kgm ²)	Mot. (Gr)
PR-AC	454	5430	15	15,24	0,099	0,515	90S
PR-AC	456	3520	6	9,88	0,099	0,515	80

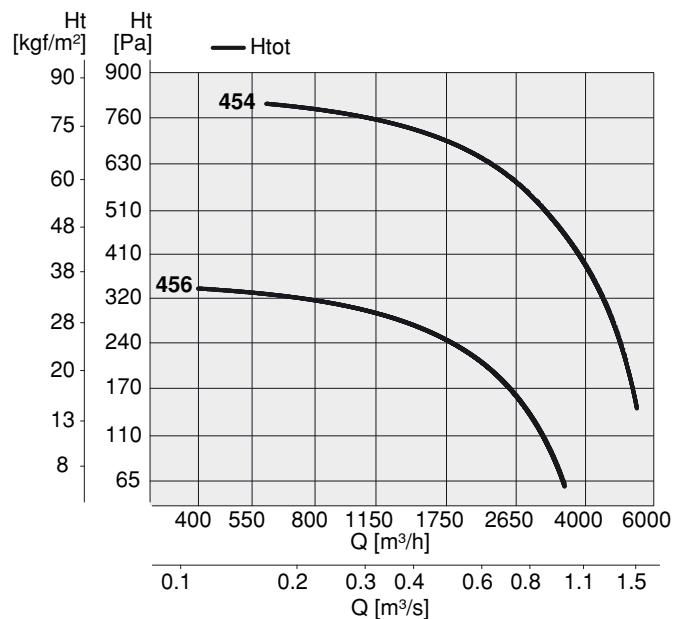



Frequenza 50Hz – Temperatura dell'aria 15°C – Pressione barometrica 760 mm Hg – Peso specifico dell'aria 1,22 kg/m³
 Frequency 50Hz – Air temperature 15°C – Barometric pressure 760 mm Hg – Air specific weight 1,22 Kg/m³

Lp: livello di pressione sonora rilevato a 1,50 m - **Lp:** sound pressure level measured at 1,50 m

PR-AC 500							
Tipo Type	Modello Model	U	P	Pm (kW)	In (A)	IP/CL	Lp dB(A)
PR-AC	504	T	4	2,20	5,40	55/F	72
PR-AC	506	T	6	0,75	2,40	55/F	62
PR-AC ATX	504	T	4	2,20	5,07	55/F	72
PR-AC ATX	506	T	6	0,75	2,23	55/F	62

Limiti d'impiego - Operational limit							
Tipo Type	Modello Model	Q max (m ³ /h)	Pt min (mm H ₂ O)	C max (m/s)	S (m ²)	Pd ² (kgm ²)	Mot. (Gr)
PR-AC	504	8980	39	19,96	0,125	0,70	100L
PR-AC	506	5680	16	12,63	0,125	0,70	90S

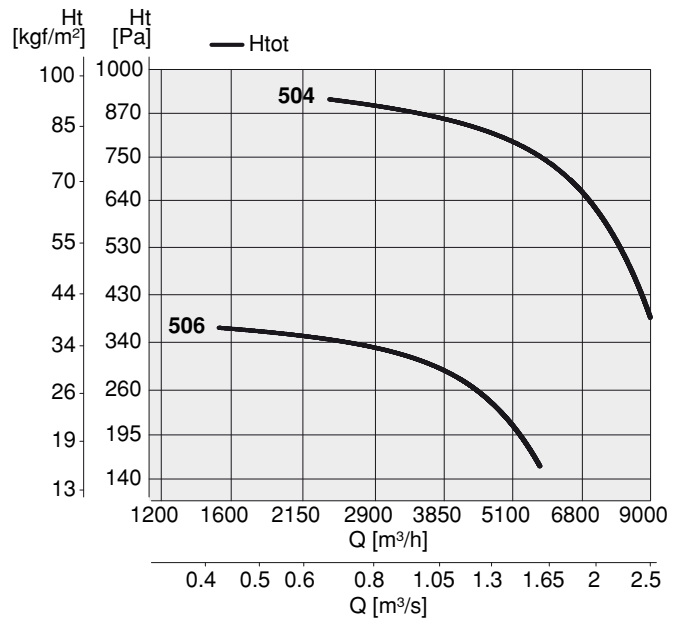

PR-AC 560							
Tipo Type	Modello Model	U	P	Pm (kW)	In (A)	IP/CL	Lp dB(A)
PR-AC	564	T	4	4,00	8,50	55/F	73
PR-AC	566	T	6	1,50	4,20	55/F	64
PR-AC ATX	564	T	4	4,00	8,60	55/F	73
PR-AC ATX	566	T	6	1,50	4,04	55/F	64

Limiti d'impiego - Operational limit							
Tipo Type	Modello Model	Q max (m ³ /h)	Pt min (mm H ₂ O)	C max (m/s)	S (m ²)	Pd ² (kgm ²)	Mot. (Gr)
PR-AC	564	12230	45	21,50	0,158	0,90	112M
PR-AC	566	7940	19	13,96	0,158	0,90	100L

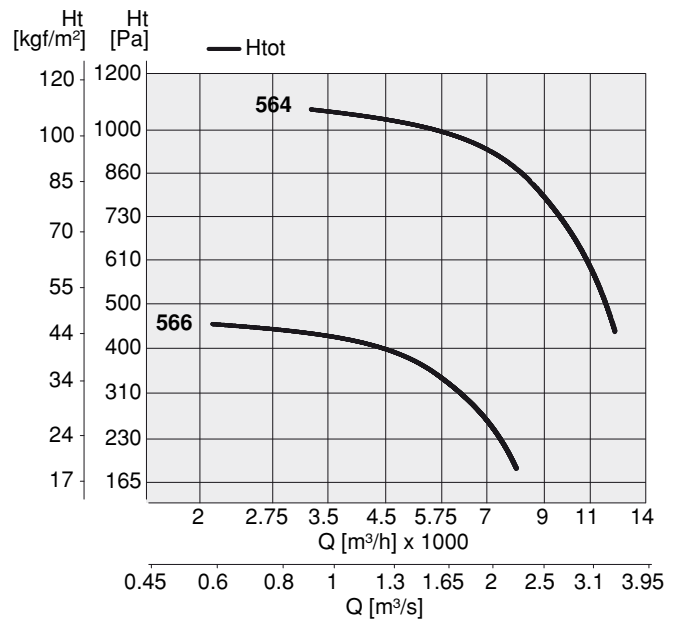

PR-AC 630							
Tipo Type	Modello Model	U	P	Pm (kW)	In (A)	IP/CL	Lp dB(A)
PR-AC	634	T	4	5,50	11,30	55/F	74
PR-AC	636	T	6	2,20	5,30	55/F	65
PR-AC ATX	634	T	4	5,50	11,20	55/F	74
PR-AC ATX	636	T	6	2,20	5,60	55/F	65

Limiti d'impiego - Operational limit							
Tipo Type	Modello Model	Q max (m ³ /h)	Pt min (mm H ₂ O)	C max (m/s)	S (m ²)	Pd ² (kgm ²)	Mot. (Gr)
PR-AC	634	17450	62	24,73	0,196	1,50	112M
PR-AC	636	11380	27	16,13	0,196	1,50	132S

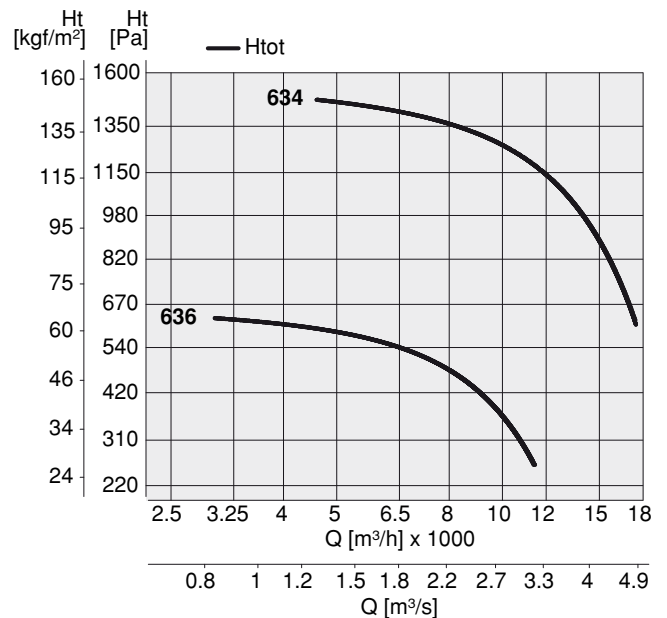

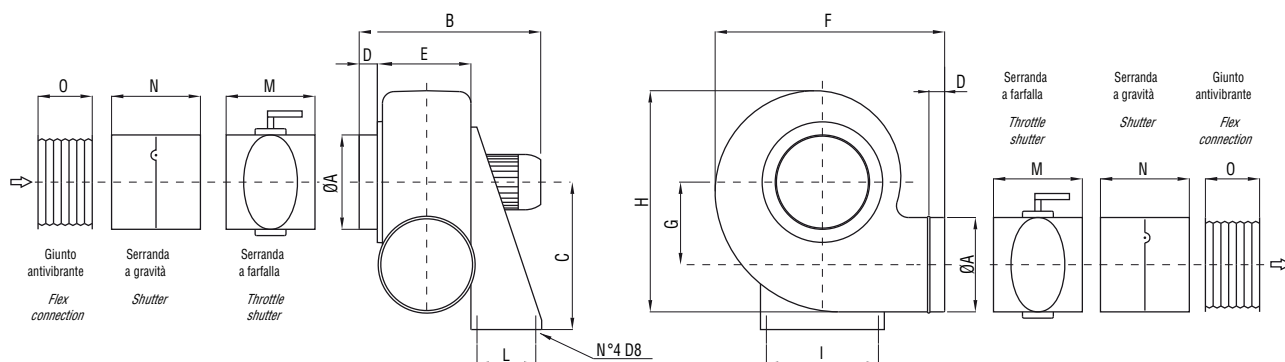

TIPO TYPE	ØA	B	C	D	E	F	G	H	I	L	M	N	O	kg
20	160	400	250	30	150	400	140	400	195	100	120	210	170	10
25	200	440	310	30	180	480	183	500	252	100	120	250	170	12
28	225	490	350	30	190	520	208	560	277	120	120	275	170	22
31	250	500	410	40	200	560	240	670	315	150	120	300	170	31
35	280	520	445	40	220	600	260	700	345	150	150	330	170	38
40	315	550	495	40	240	675	290	790	325	170	150	365	170	38
45	355	630	550	40	265	730	324	870	370	170	150	405	170	46
50	400	655	630	50	355	796	360	956	289	197	150	-	170	115
56	450	725	710	50	365	870	410	1045	289	237	590	-	170	130
63	500	810	800	50	408	1030	445	1200	337	237	640	-	170	175

Dimensioni in mm / Dimensions in mm